



GLAZING GUIDE

**The SEAC Glazing guide is not a substitute for the acknowledged rules.
It is to promote professional glazing by giving tried and tested suggestions for
solutions.**

Table of Contents

Introduction	2
SEAC's new generation of glazing packer	3 - 4
General/Colour codes	5
Definition	6
Glazing-in process	7
Glazing Procedure	8 - 9
Dimensioning and position of the glazing packers	10
Material of the glazing packers	11 - 12
Interaction of Sealants	13 - 14
Properties of the glazing packers	15
Systematic sketches	16
Glazing suggestions for flat units	17 -18
Special glazing solutions	19 – 24
Glazing Suggestions for Self Locating Packers	25 – 26
Glazing Suggestions for higher Stability & Security	27 – 32
Compensating Blocks	33
Important Note	34

Introduction

Packers are the sole connection between the frame and the edge of the glass and thus assumes tasks which have a decisive influence on the permanent guarantee of the functions:

- load support
- ease of movement of the leaf
- securing of a circumferential vapour pressure compensation
- protection of the edge compound of the insulating glass
- avoiding glass/frame contact
- preventing the glass product from slipping
- relieving the glass edge.

The advent of functional and insulating types of glass, the increase in the weight of glass and the growth in the various profile systems make it necessary to adapt the packer properties.

This guide shows the variety and differences in application. Various frame constructions and support conditions demand separate glazing packer solutions which we can offer you.

SEAC's New Generation of Packers

The universal packer

- Elastic support
- Permanently stable base
- Bridging channel
- For all glass with irregularity in the edges of the glass
- non-deteriating
- designed to support glass during its life
- material is compatible with most types of sealants
- resistance to temperatures from
- -20°C to +80°C

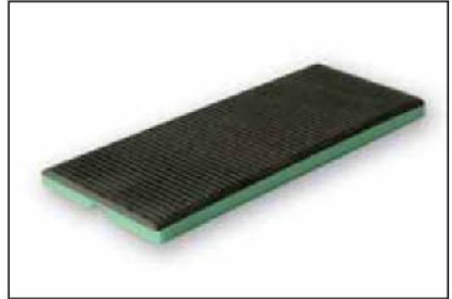

Length 100mm

The universal packer with steel insert

- high stability because of the 1.5 mm thick steel layer
- non deteriorating
- designed to support glass during its life
- suitable in cases where the window pane is thicker as the casement used when glass weight requires increased support, helps protect uneven glass edges because of the elastic surface of about 70° Shore A



Length 100mm

Note: The Universal packers are not ex-stock.

SEAC's New Generation of Packers



Length 100mm

The standard glazing packer

- designed to be used in all types of standard glazing applications
- stable bar system gives outstanding load-bearing capacity material is compatible with most types of sealants
- non deteriorating
- designed to support glass during its life
- withstanding temperatures from -20°C up to $+80^{\circ}\text{C}$



Length 100mm

The self locating packer

- stable bar system gives outstanding load-bearing capacity
- non-deteriating
- designed to support glass during its life
- due to the 2 locating lugs this unique glazing packer bonds itself into the double glazing sealant

Note: The Universal packers are not ex-stock.









General

The tasks of glazing packers are essentially to be assessed in an installed state, with the glazier having to observe the following points:

- They ensure that the glass edges do not have contact with the frame at any time, in order securely to prevent damage to them.
- Keeping the frame and the casement in the correct position without distortion or turning on edge, and ensuring a flawless function.
- The spacer packers also assume a bearing function, depending upon the kind of opening of the casements, and ensure installation free of pressure.
- Distributing and compensating the weight of the glass in the frame.
- The load support is done via the packers to the fittings and then further to the fix points and the supporting parts of the window.
- The frames must be dimensioned stably so that the weight of the glazing units is supported without faults.
- If the glass unit is to stabilise the frame construction, consultations with the glass manufacturer are necessary at all costs.

The Colour Codes

The thickness of the glazing packers is determined by the colours

1mm =		white	6mm =		black
2mm =		blue	7mm =		transparent
3mm =		red	8mm =		grey
4mm =		yellow	10mm =		brown
5mm =		green			



Definition

The glazing packers have various functions to fulfil, for which reason it appears important for us to define **the function**.

1. **Support packers**
conduct the weight of the glazing unit to the frame construction.
2. **Spacer packers**
ensure the distance between the edge of the glass and the base of the rebate and guarantee installation free of pressure. They sometimes assume the task of support packers in alterations to the function of the casement.
3. **Bridge packers**
ensure a circumferential vapour pressure compensation on a flat base of the rebate. They are used as support or spacer packers.
4. **Compensating blocks**
act as a section compensation (dependent upon system) and ensure a flat support. The compensating blocks form the base for the glazing packers. **They are not a replacement for glazing packers.**

The principle that “the edge of the glass is not to be overburdened” is to be observed as a matter of principle.

The breadth, length, stability and compatibility as well as the hardness of the material essentially contribute to this together with the arrangement of the glazing packers.

Glazing-in Process

In side-hung or tilt-turn windows, a start is made with the insertion of the packers on the bottom edge of the glazing rebate or on the compensating blocks.

The thickness of the packer should be at least 5 mm.

The glass unit is positioned on the lower packers and carefully tipped into the frame. Then, a packer is inserted on the upper end of the closing side (i.e. diagonal to the corner support). **To avoid damage to the edges of the glass**, spacer and support packers must be inserted in accordance with the function of the window (see our glazing suggestions on page 20ff.). The packers must sit tight and must not change their position later on, for which the self locating packer is to be recommended. Other packer constructions without location lugs must be fitted according to the provisions of the sealant industry.

The packer must always be aligned **straight** and **parallel to the edge of the glass** (Fig. 3, see **impact padding**). It must support the full thickness of the glazing unit in order to guarantee an optimal load support.

In glazing, the specific directives of the glass and frame manufacturers and those of the sealant supplier for the edge compound must also be observed.

The self locating packer with 2 location lugs

- quick mounting
- due to the 2 location lugs this unique glazing packer bonds itself into the double glazing sealant.
- asymmetric bar system gives outstanding load-bearing capacity
- material is compatible with most types of sealants
- non-deteriating
- designed to support glass during its life
- withstands temperatures from -20°C to +80°C
- resesed at each end to help adjustment/removal



View from below

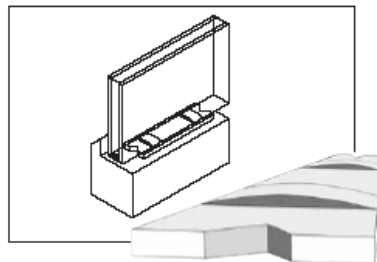

No adhesives may be used to fix glazing packers.

Glazing Procedure – Example of Installation



Figures 1 & 2: Insertion of the packers on the closing side



Fig 3: Ready Glazed Corners (packers inserted) of a tilt window

Impact Glazing

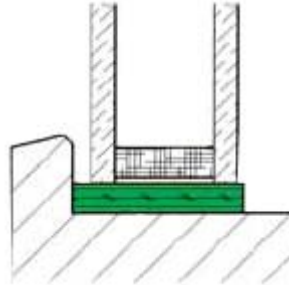

In impact glazing, it is ensured that also the invisible area of the edge of the glass is supported.

Glazing Procedure – Example of Installation

The load-bearing capacity is not only based on the material and the length of the packers, but is also dependent upon the pad construction. The examples shown below are used to calculate the actual load-bearing area. The smaller the load-bearing area, the larger the load on the edge of the glass becomes. In unfavourable overlappings, for example offset of the edges of the glass or glass edges not at right angles, the risk of breakage of glass can be increased.

Adjust and compensate the offset of the unit edge through the hardness of the packer. **Please don't work this way:**

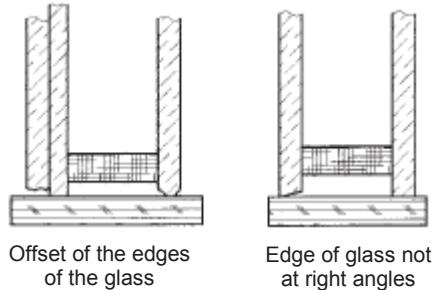

Examples of packer constructions:

The comparison of SEAC packers with other block geometries

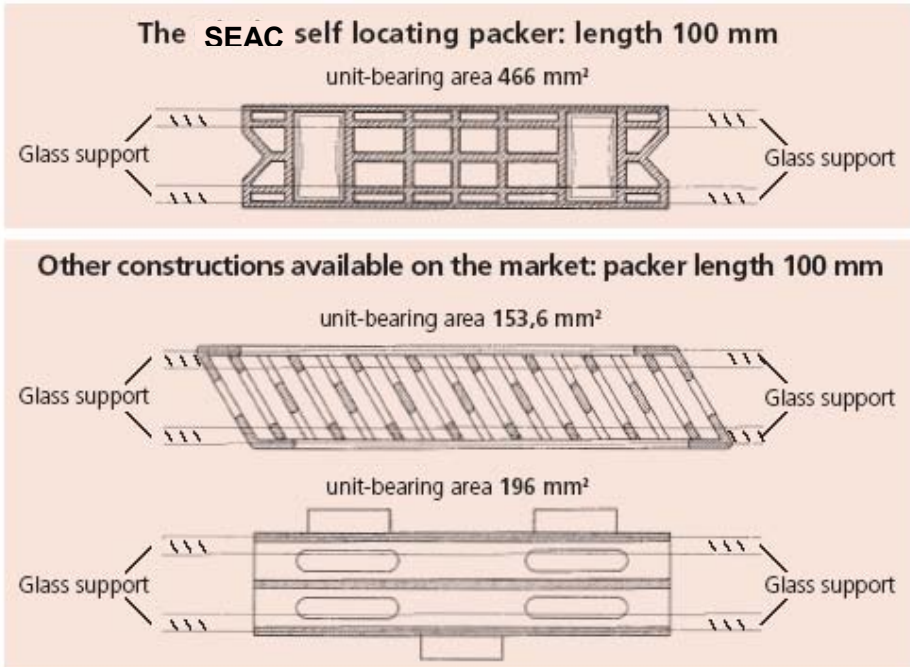

Note: For large-area glazings $\geq 10\text{m}^2$ and/or a weight $>500\text{ kg}$ we recommend a packer length per packer position of 200 mm (corresponds to 2 packers) - see Universal packer page 6

Dimensioning and Position of the Packers

The arrangement of the packers is based on the function and kind of opening of the window (see pages 20/21).

Generally speaking, the distance of the packer from the corners of the glazing unit should be about one packer length.

For special frame constructions (wide, fixed units, e.g. shop windows), the support packers must sit above the fitting points of the frame. The height of the packers is based on the earance (see sketch, p. 31).

The packer thickness should be at least 5 mm. For units with a smaller format, edge length up to about 500 mm, the packer thickness can be reduced to 3 mm, **as an exception**. The packer width is based on the thickness of the glazing unit. It should be about 2 mm wider

than the glazing unit (see sketch).

For certain glass products or glazings, the guidelines rescribed by the glass or insulating glass manufacturers are to be observed.

The packer thickness should be 100 mm as a rule, in order to reduce point loads and thus the risk of breakage of the insulating glass unit.

Our years of experience have shown that the various kinds of windows and window openings are not overburdened with 100 mm long packer materials. We shall continue to prefer this length of glazing in the future.

Example: A packer length of 80 mm has a 25% lower support area than a packer length of 100 mm.

Packer distance = Packer thickness*

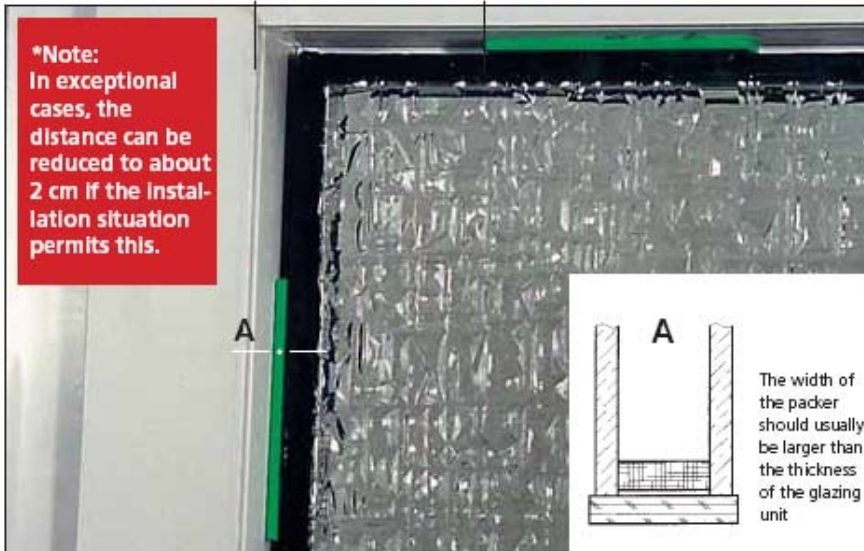

Example of a professional glazing with a packer thickness of 5 mm and a packer length of 100 mm, taking the correct arrangement and the correct distances into consideration.

Attention: The vapour pressure compensation openings must not be covered by the glazing packers.

Material of the Glazing Packers

SEAC's glazing packers are made of a special plastic. They are produced from a "virgin" (new) material. They possess a sufficient permanent pressure resistance and aging-resistance. The latter is dependent upon the load-bearing capacity of the material, the packer length and the packer construction. They must not cause any splintering on the edges of the glass.

The packer must not alter its properties due to air humidity, contact with other materials or other influences (see extracts of the report - **Interaction of sealants, insulating glass info**, Technical recommendation 3/97, page 16).

The compatibility of the packer with the contact agents must have been proved.

PVC and metal windows should be glazed with approved plastic packers.

For glass compounds (e.g. with PVB foil, cast resin etc.) attention is to be paid to the material compatibility of the packers with the intermediate layers of the glazing units and the edging compound of the insulating glass. The same is true for sealing profiles and sealants. Here too, a test is recommended.

The compatibility with the contact materials must be proved, so that the insulating glass is not damaged in this area (e.g. dissolution of the edging compound, opacity of the insulating glass unit).

As also stipulated in Technical Directive No. 3 "Blocking of glazing units", the mutual compatibility of the materials used will have to be permanently ensured.

The compatibility of glazing packers supplied by SEAC has been successfully tested and certified.

The materials used must be permanently compatible with one another.

Material of the Glazing Packers

Test result for proof of the incompatibility of two materials in contact (in this case, packer and edging compound).

Effect of missing compatibility proof

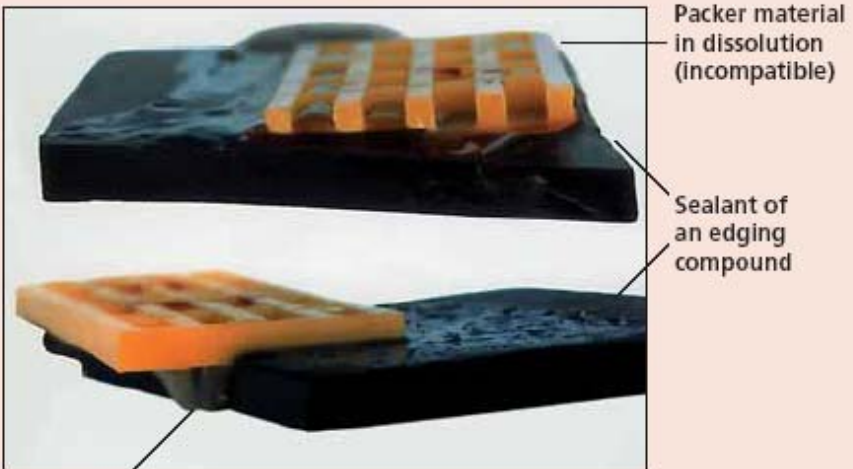

Dissolved packer material

Glazing packer material reacts via the contact with the edging compound material and dissolves (plasticiser migration).

Interaction of Sealants

If two differing, heterogeneously composed materials are brought into contact, interactions can occur between them. One of these interactions can comprise one or more of the components of one material transferring into the other one. This process is generally termed migration. Through it, the properties of the two materials can change in a lasting and disadvantageous way and thus also reduce or even completely prevent the usefulness of the combination of materials.

In polymer materials, a special case of these migration processes is the transfer of plasticiser(s) of one material into the other, so-called plasticiser migration, a very frequent and sometimes also disturbing phenomenon.

The technical rules, and in particular, the standards, have taken this phenomenon into account. This standard therefore defines the term of compatibility: **"Materials are compatible with one another if no damaging interaction occurs between them"**.

A large number of further standards, guidelines and recommendations make reference to the term of compatibility for combinations of materials or demands that work materials must be compatible with one another in order to avoid restrictions of use and failures.

Primarily, there are two specific elements which play a large role here with regard to compatibility or incompatibility:

- **Glazing sealants**
- **Glazing packers**

If damaging interactions between the insulating glass sealant and a contact work material are to be avoided, an examination of the compatibility under suitable test conditions is indispensable. A forecast of the exclusion of interactions is practically impossible.

The relevant standards and guidelines demand a compatibility of the contact work material (glazing sealant, glazing packer) with the edge compound of the insulating glass. **From it, the demand can be implicitly derived that anyone wishing to use a certain contact material (sealant, pad etc.) must prove its suitability accordingly.**

The inversion of this demand is not admissible under any circumstances, i.e. it is not the task of the manufacturer of an insulating glass sealant to make responsible tests of the compatibility of his product with that of various contact materials. The consequences of the interactions between the insulating glass sealants and the contact materials are of great importance for practice, in particular with regard to the financial demands in the event of damage.

Interaction of Sealants

The compatibility of the edge compound with the glazing packer material is based on comparable factors, i.e. on the one hand the packer can absorb materials from the edge compound or even pass on materials to the edge compound itself. The appearance here is similar to that of the sealant incompatibility.

If the packer absorbs materials from the edge compound, softening, discoloration, separation of liquid components right down to the complete dissolution of the packer can occur. Vice versa, the packer can also pass on materials to the edge compound, i.e. this can, similar to the description above, result in softening, discoloration, separation effects or similar.

Experience has however shown that damage of the packer is the most frequent cause for complaints.

Here, a certain raw material was determined as being especially critical, polystyrene. Pads of polystyrene or mixtures containing polystyrene frequently proved to be incompatible with customary edge compound sealants.

In the complex of incompatibility of insulating glass sealants with certain contact materials mentioned here, e.g. glazing sealants and glazing packers, there are concrete requirements with regard to the exclusion of damaging interactions stated by standards and directives.

A forecast with regard to interactions is generally not possible. For this reason, a corresponding examination for an exclusion of damage on the basis of these phenomena is indispensable. This test must extend to all possibilities of interaction: inner PIB seal and outer sealing as well as the contact materials, if necessary in comparison with an inert reference material.

Properties of the Glazing Packers

In glazings with a rebate area free of sealant, the packers must be secured against displacement or slipping, so that the edge of the glass does not touch the frame. The materials used to secure the packers must be compatible with the edge compound and the packer.

No adhesives may be used to fix glazing packers. Packers with a self-inhibiting effect are to be preferred here (e.g. self locating packer).

With a level base of the rebate, bridge packers are necessary so that the vapour pressure compensation is guaranteed. There must be no enclosed air cavities.

Likewise, the sealant-free rebate area must be opened towards the outside. The packers may not prevent or block the vapour pressure compensation.

In heavy units of compound or compound safety glass, we recommend the universal packer, which compensates the offset of the panes caused by the manufacture through an elastic packer surface (hardness approx. 70° Shore A) with a high permanent pressure resistance, in order to prevent a punctual load on the edge of the unit (recommended in TR3 - Technical Directive No. 3 Blocking of glazing units- as well as by manufacturers of insulating glass and of sealants).

The universal packer

The universal packer offers optimal glazing, in particular with heavy glass weights and irregularities in the edges of the glass.

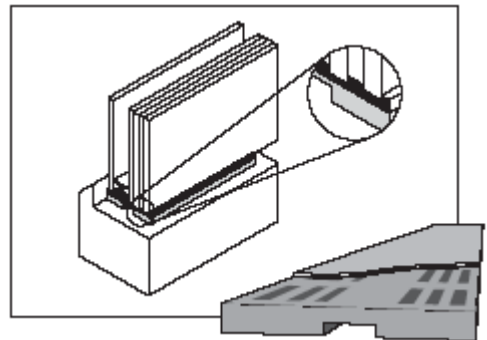
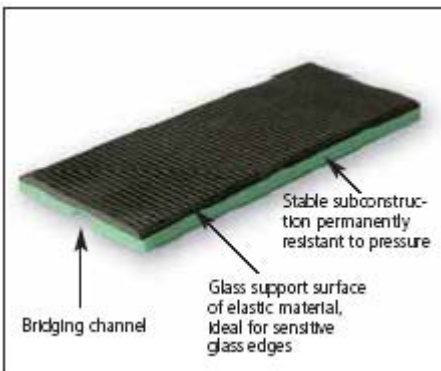

- elastic compensation for the irregularity on the edges of the glass
- permanent weight support with a stable base
- vapour pressure compensation through bridging channel

Attention: The universal packer is particularly suitable for structural glazing and is recommended for this purpose by sealant manufacturers.

System Sketches

Frequently, the packer is thoughtlessly inserted wrongly underneath the edge of the insulation glass, thus increasing the risk of breakage of glass.

Wrong glazing packer position:

The following sketches give schematic portrayals of how a breakage of glass can come about or the edge compound can be destroyed.

The following sketches give schematic portrayals of how the risk of glass breakage can be increased and the edge compound destroyed.

Correct glazing packer position:

For this reason, we recommend the complete support of the thickness of the glass element

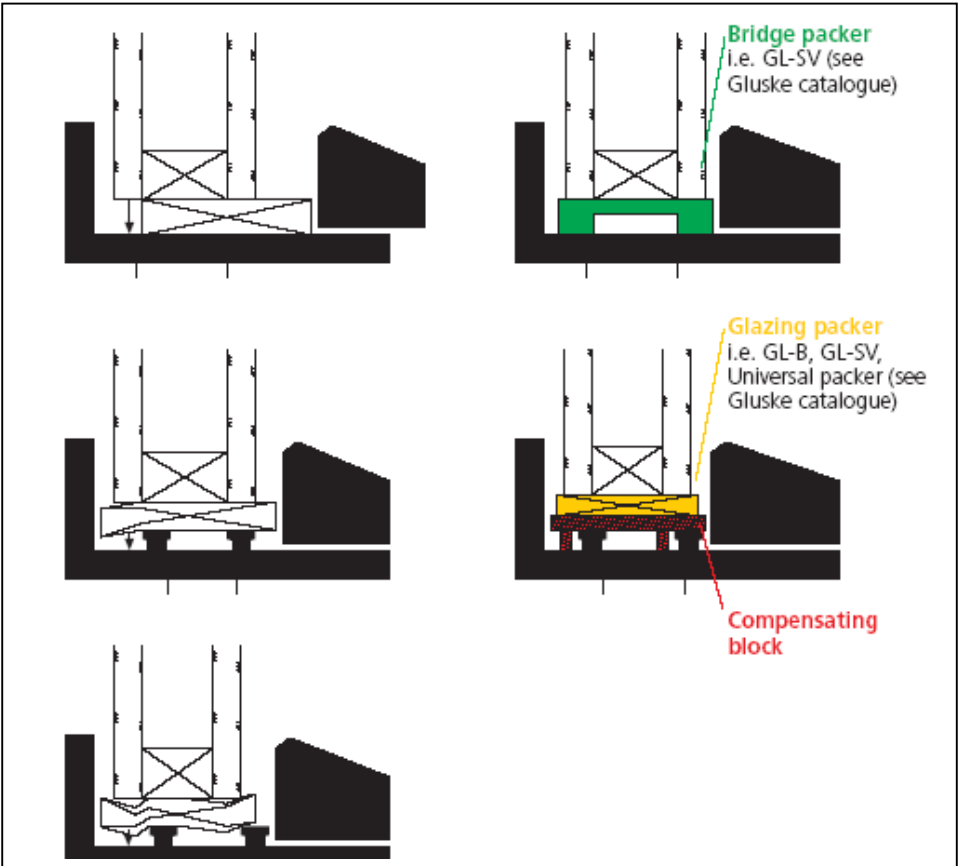

Glazing Suggestions for Flat Units

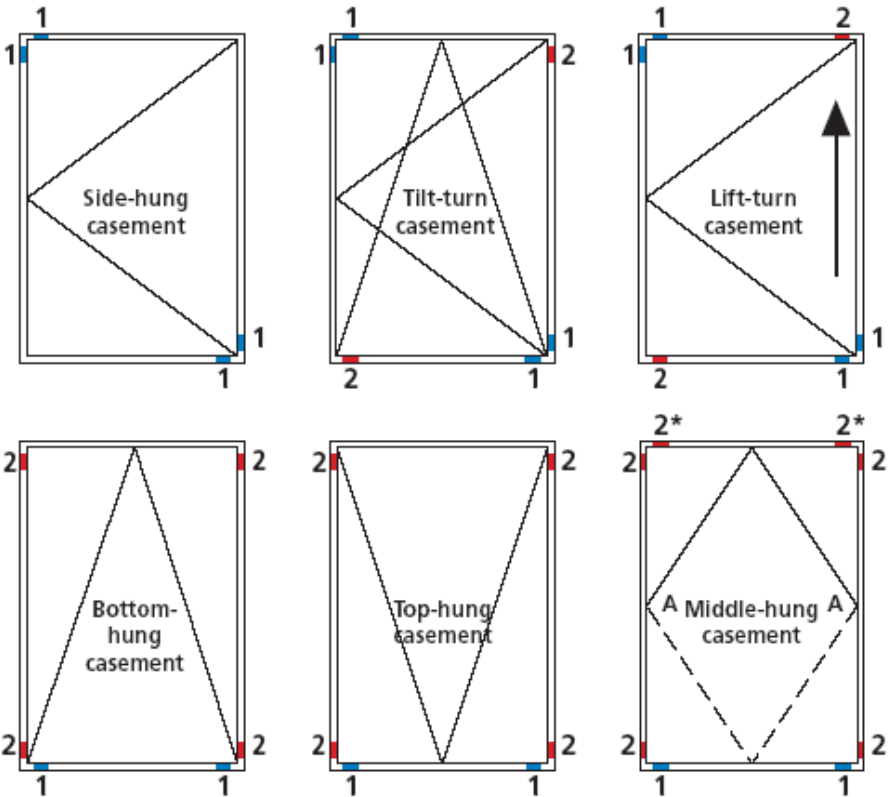

- 1 Support packers
- 2 Spacer packers

1* With glazing units more than 1m in width, 2 support packers of at least 10 cm in length should be above the fulcrum.

2* become support packers with the casement turned over.

A - recommendation: For middle-hung windows made of plastic sections, it is recommended that you ask the section or frame manufacturer for the recommended glazing on the central fulcrum. Possibly, double glazing above and below the fulcrum is necessary.

Glazing Suggestions for Flat Units

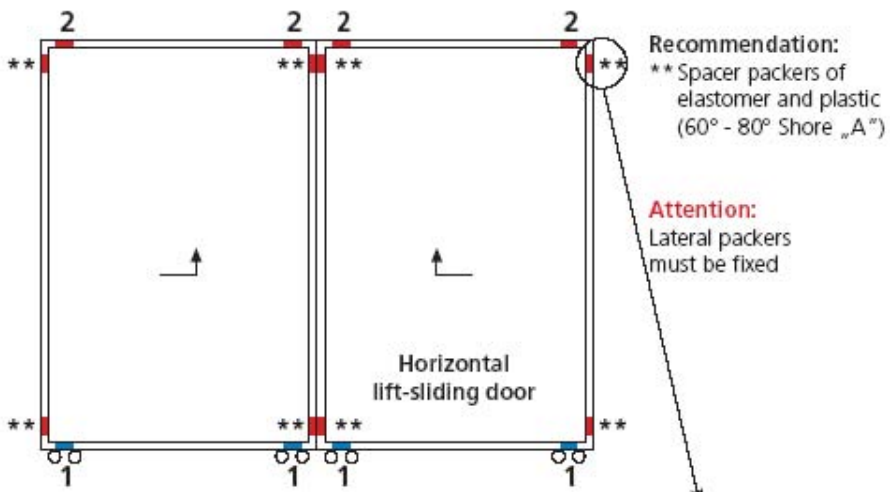
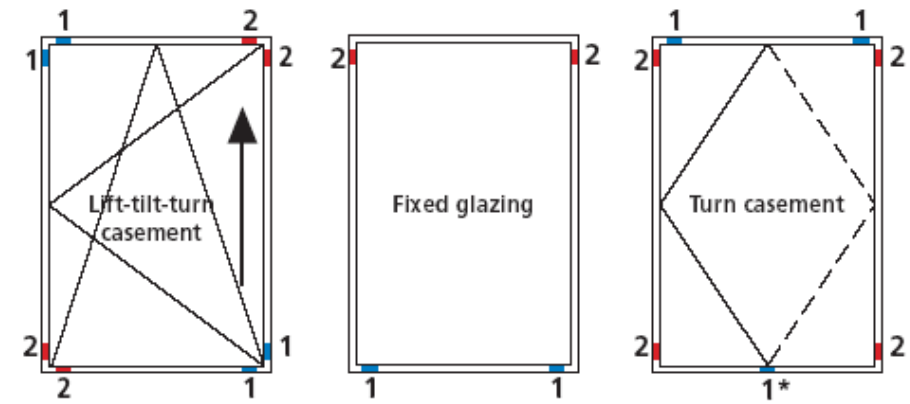

The hook packer

- Maintains the correct space to the outer edge of the glass
- Hook prevents slipping

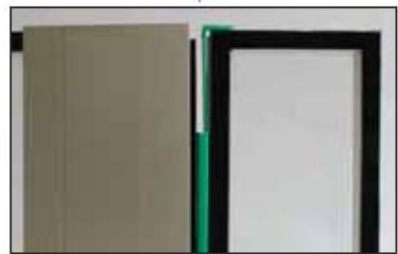

Special Glazing Solutions

The glazing unit will have to be supported by the entire width, so as to allow the loads being absorbed in an optimal way. A major prerequisite in this respect is a substructure with a sufficient load-bearing capacity.

In the case of an offset in the substructure (due to the system) or of protruding glazing units, a packer with a steel insert is required, so as to absorb the bending forces thus generated.

Special cases, such as structural glazing or point loads, will have to be sorted out and agreed individually, unless the system manufacturer provides his own suggestions.

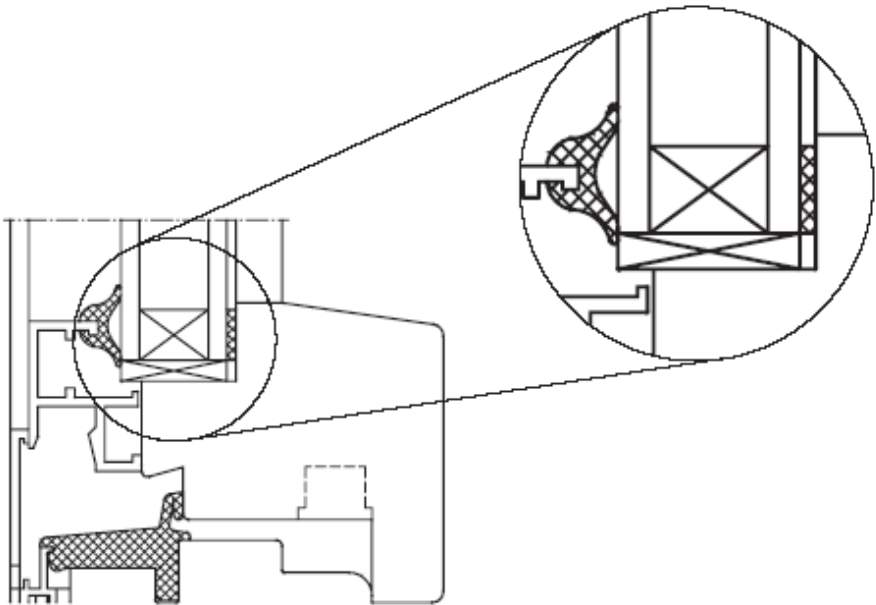

The Universal packer with steel insert

The packer for higher glass weights and bending forces

- suitable in cases where the glass unit is thicker as the casement
- used when glass weight requires increased support
- helps protect uneven glass edges because of the elastic surface of abt. 70° Shore A
- non deteriorating
- temperature resistance from -20° C to + 80°C



Special Glazing Solutions

In the chapters above, standard glazings were shown which refer to rectangular formats and vertical glazing.

The following special forms are to be adapted to the constructional situation in individual cases, and it is recommended that the manufacturer of the profiles is consulted. The glazing suggestions below are based on experience and the static requirements.

Curved simple or insulation glass

System 1

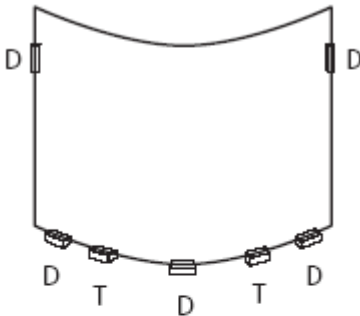

Bent simple or insulation glass must be glazed in the same way as flat glass units.

In system 1, the weight of the glass on the lower curved edge of the glass is transmitted via the support packers to the frame construction and then further to the holding construction.

System 2

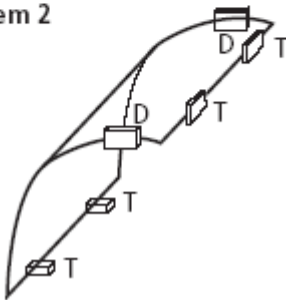

In system 2, the glass weight and the wind load are distributed to the edge of the glass. Thus must be particularly observed when upporting. Curve tolerances must be absorbed.

Memento Glazing guide of Saint-Gobain Glass Edition 2000

T = Support packer, elastic material, hardness approx. 70° Shore A. Additional packer in order to avoid tipping.

D = Likewise elastic material, hardness approx. 70° Shore A. Weight only lays on the support packers.

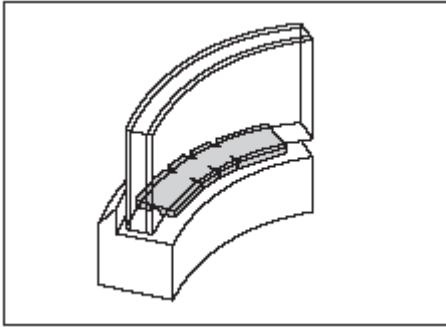

Packer Length 120mm

The Multiflex packer



The packer for bent glass units

- Adapts individually to a number of radii thanks to its notches
- ensures vapour pressure compensation thanks to its continuous ventilation channel
- offers a large support surface and an outstanding load absorption thanks to its length of 120 mm

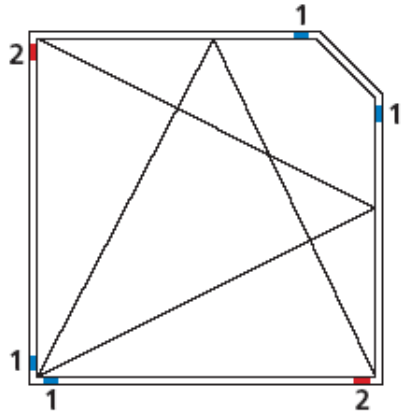
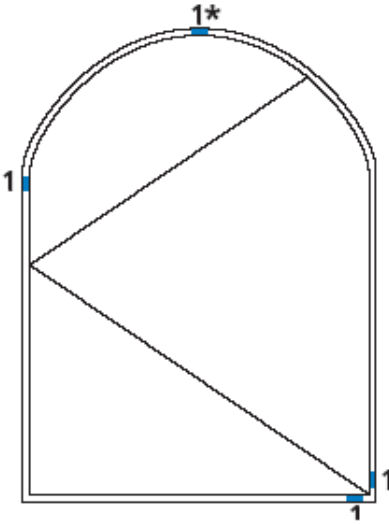

Special Glazing Solutions



- 1  Support packers
- 2  Spacer packers
- * Glazing packer material made of elastomer

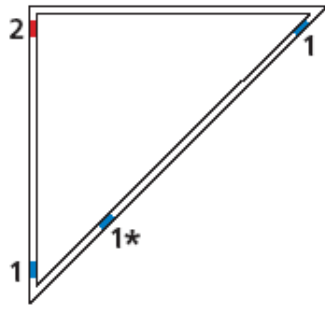



Note:

The possibilities shown merely represent some examples. Constructions not shown are to be decided in individual cases. General glazing guidelines should be considered.

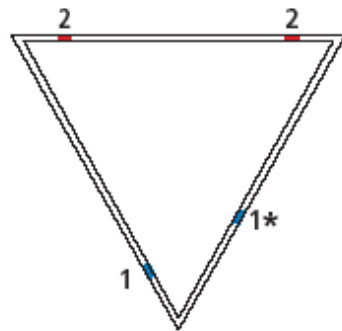
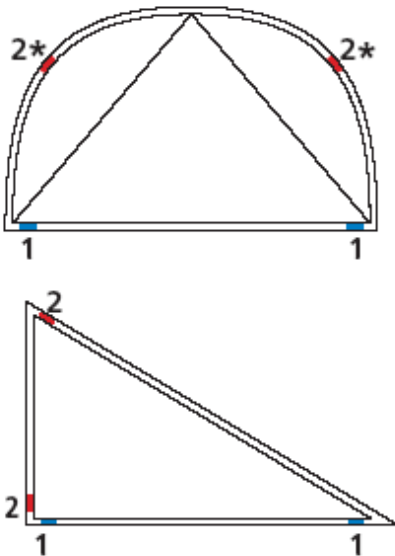
Special Glazing Solutions



- 1  Support packers
- 2  Spacer packers
- * Glazing packer material made of elastomer

Special Glazing Solutions

The Superflex packer

The solution for every model unit glazing

- adapts to every model shape
- prevents punctual overloading through 100% support
- ensures ventilation of glazing rebate thanks to the ventilation channel

Ideal for:

- curved windows or segmental arch windows
- triangular shapes
- special shapes

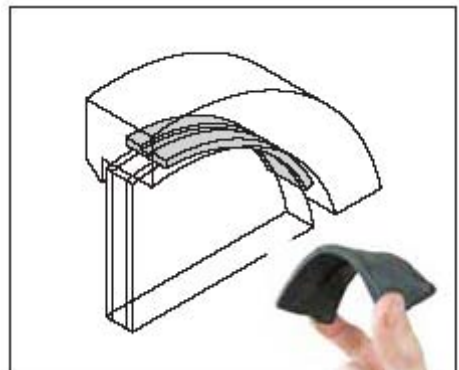

Super-elastic, but solid

Glazing Suggestions for Self Locating Packers

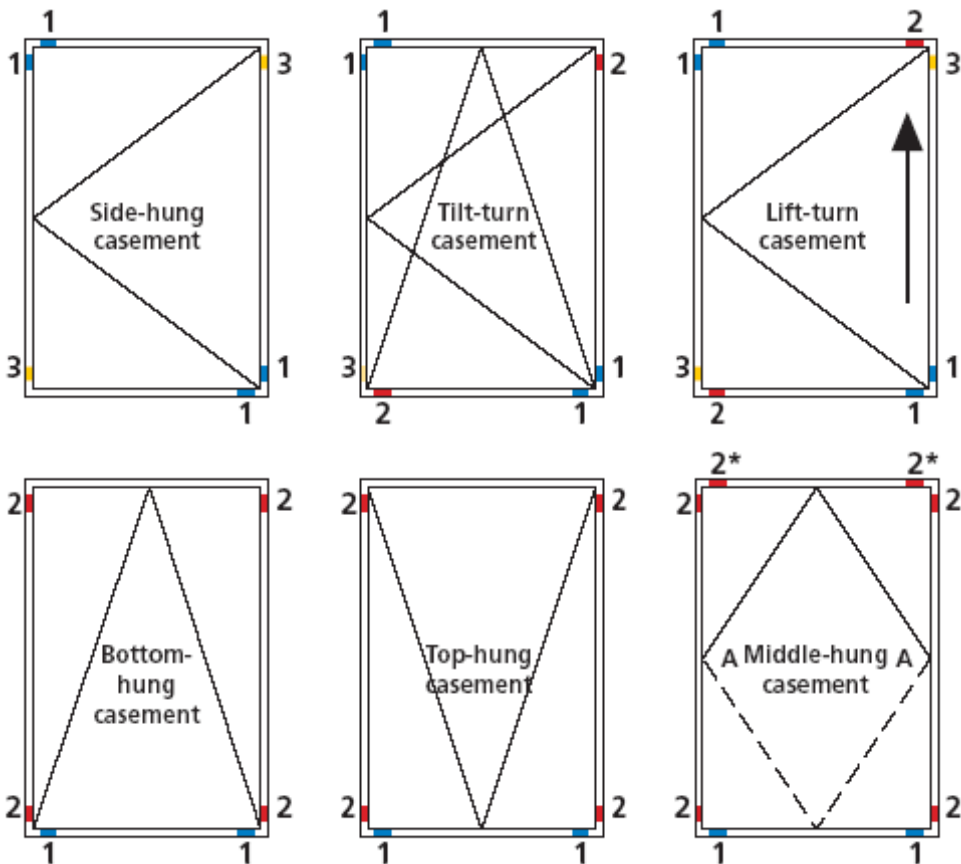

- 1 Support packers
- 2 Spacer packers
- 3 In the use of self locating packers, a counter-glazing = spacer packer is recommended.

1* With glazing units more than 1 m in width, 2 support packers of at least 10 cm in length should be above the fulcrum.

2* become support packers with the casement turned over

A - recommendation: For middle-hung windows made of plastic sections, it is recommended that you ask the section or frame manufacturer for the recommended glazing on the central fulcrum. Possibly, double glazing above and below the fulcrum is necessary.

Glazing Suggestions for Self Locating Packers

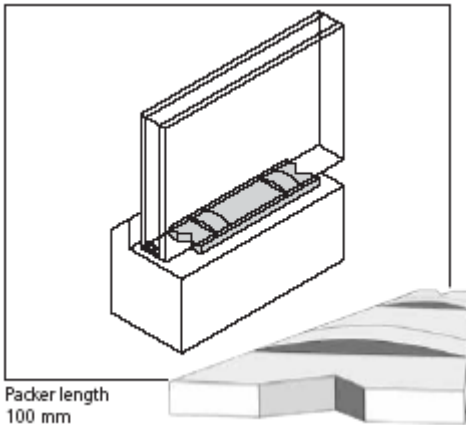
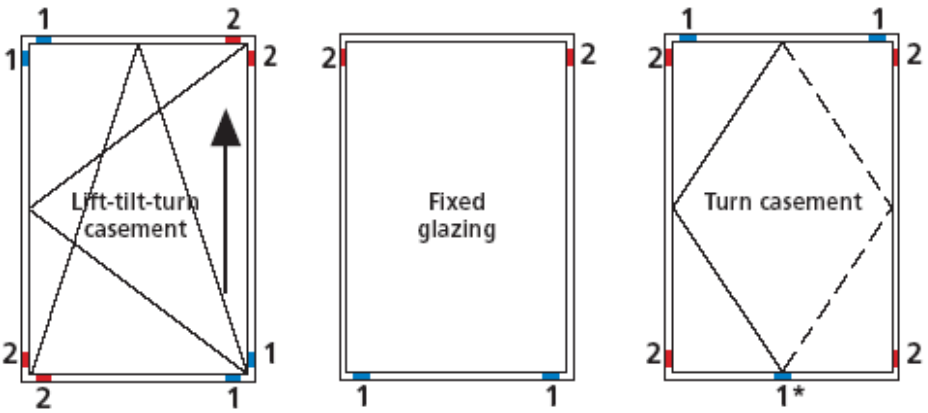

The self locating packer

- quick mounting
- due to the 2 location lugs this unique glazing packer bonds itself into the double glazing sealant.
- asymmetric bar system gives outstanding load-bearing capacity
- material is compatible with most types of sealants
- non-deteriating
- designed to support glass during its life
- withstands temperatures from -20°C to +80°C
- resesed at each end to help adjustment/removal

Glazing Suggestions for higher stability and security

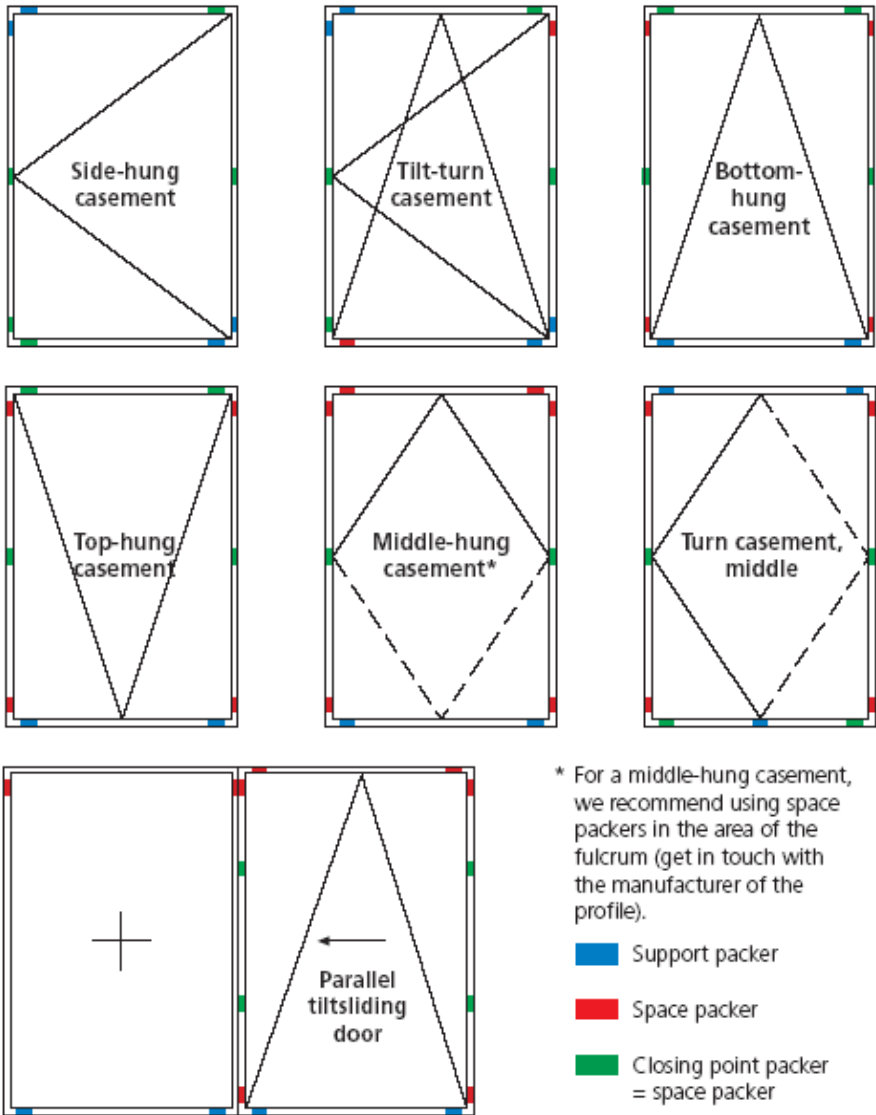

Note: For long, unsupported lengths of sections, we recommend arranging the additional spacer packer in about the middle in order to reduce the deflection.

Glazing Suggestions for higher stability and security



Extreme example of a closing point glazing in the finished version. The closing point glazing is a spacer glazing and fills the clearance.

An additional glazing is recommended at the closing points in order to reduce the risk of levering open. We recommend our universal packer for this.

For plastic windows, glazing packers must also be inserted at the closing points. Thickness of closing point packer = clearance/rebate area.

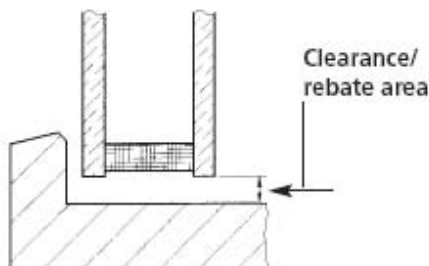

Attention:
the closing point glazing is done at the end and is a spacer glazing.

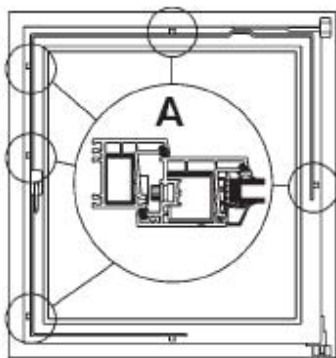

A Closing point = glazing point
Please observe the basic demand that the edge of the glass must not be overburdened or damaged. Example on the basis of a plastic window (also transferable to other frame materials).

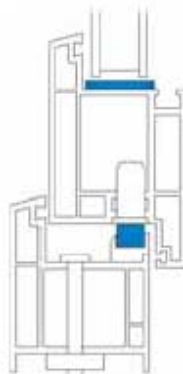

A space packer is positioned directly above the closing point.

Glazing Suggestions for higher stability and security



THE SECURITY COMPENSATING BLOCK

- WK2 tested -

Clip in the base of the compensating block



Put on the drill jig and predrill into the steel

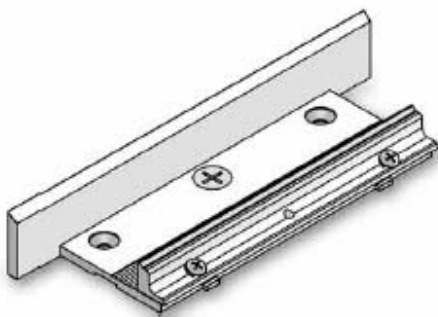

Insert the unit and block in accordance with the type of window opening

- easy to assemble
- permanently pressure-stabilized
- non deteriorating
- web system as a means of compensating steam pressure



Fit in the retaining lugs and screw them tight to ensure that the screw picks up reinforcing



Assemble the grip channel for the unit as usual



after having passed the WK2 test

Glazing Suggestions eg for higher security

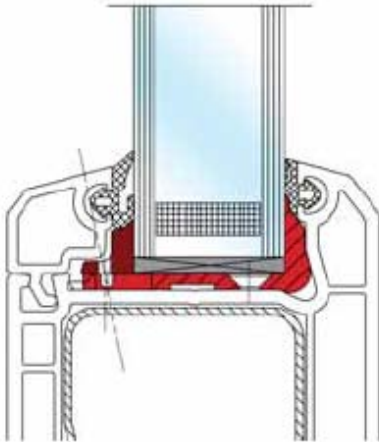

- The security compensating block has been adjusted to the relevant system, so that the way of assembling the unit has been classified as resistance class WK2*
- No modifications to the fix channels required
- The fixing channels do not require extra fixings as the retaining lugs are screwed into position which provides maximum security

* Breaking-in test WK2
Institute Vebert

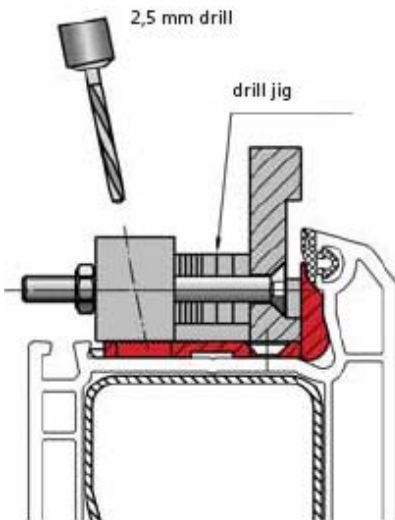

Pre-drilling with drill jig will make it easier to screw in the retaining lugs correctly

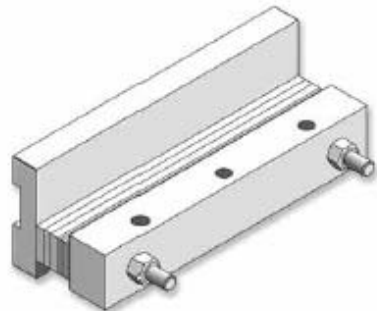

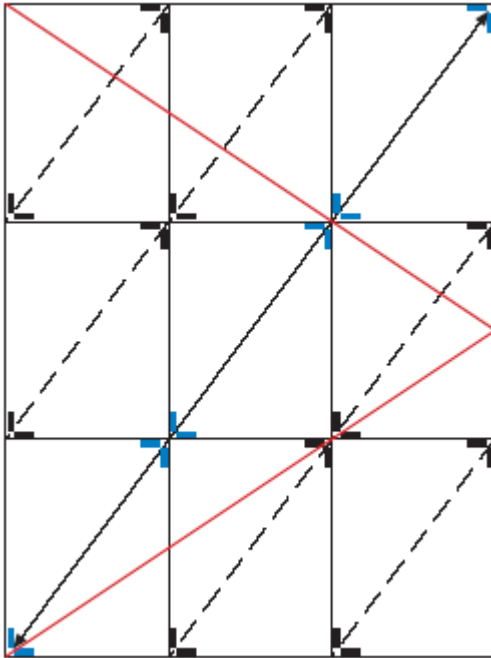

Georgian-style windows

For glazing with sub-division by bars, each field must be glazed individually in accordance with the kind of opening. A start is made with the diagonals, in accordance with the kind of opening. All the fields must be glazed.

Compound windows

A compound window is a coupling of two casements in a frame. Both casements are to be glazed in accordance with their kind of opening.

Casement windows

A casement window is a construction of two separate blind frames with the corresponding wing. Both wings have to be blocked in accordance with their kind of opening.

Glazing Suggestions eg for higher security

In overhead glazing, special attention is to be paid to the fact that the weight of the glass must be supported via the glazing point without overloading the edges of the glass and via the frame construction. Special reference is made to these construction details in the technical regulation "Overhead Glazing", drawing up by the German Institute of Construction Engineering in Berlin. There must be no contact between the glass and the frame, e.g. glass and metal or glass and glass. Slipping of the glass is to be prevented by space packers. The distance between the base of the rebate and the edge of the unit should also be at least 5 mm in this case. It is recommended to provide an elastic support at 60° - 80° Shore "A" for the edge of the unit in order to meet the special requirements in this case. Further, the particular directives of the manufacturers of the glass and the frame are to be taken into account at all costs.

Requirement made of inclined and overhead glazing

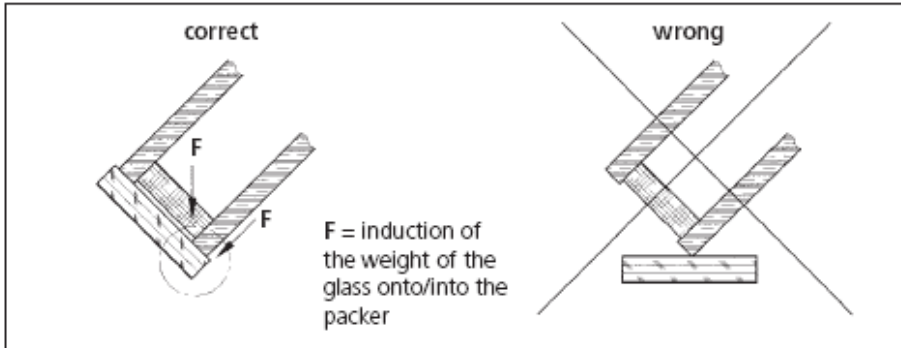

Solutions for Inclined or Overheads Glazing

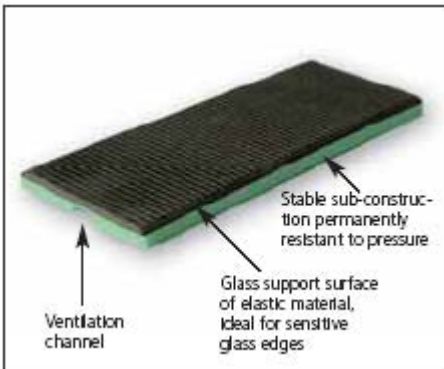

The Universal packer

- elastic compensation for the irregularity in the edges of the glass
- permanent weight support with a stable base
- vapour pressure compensation through ventilation channel

Compensating blocks

Compensating blocks act to compensate the profile (dependent upon the system) and ensure a flat base. They form the basis for the tested glazing material and are not a substitute for the glazing packer. The blocks are available with snap-in straps (see sketch).

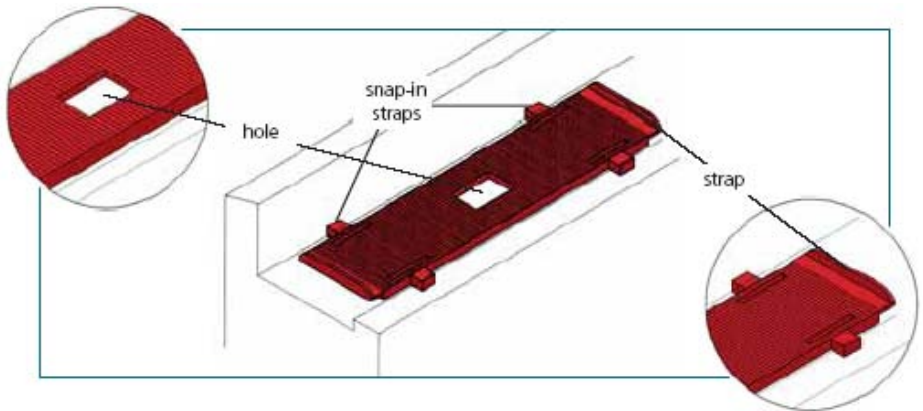

Strap:

prevents the slipping of the glazing packer on top.

Hole:

Uninhibited screwing of the frame is possible due to the recesses in the compensating block.

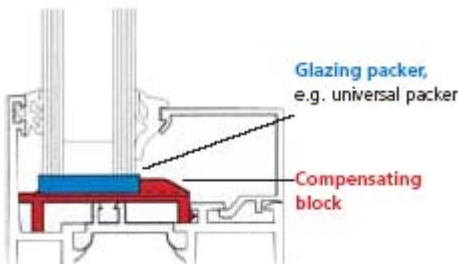

Example of application:

Aluminium profile with compensating block and glazing packer (e.g. universal packer).

We offer you individual solutions for each profile. Compensating blocks are also developed and produced specifically upon customers' request.

Important Note

This glazing guide does not exempt from the responsibility for the planning and implementation of the glazing.

The information in this guide is based on our knowledge and experience, in particular suggestions from the processing and use of our products.

Due to working conditions which are outside our sphere of influence, we recommend that suitability for purposes of processing be ensured.

No liability can be assumed for the information or oral advice given.